

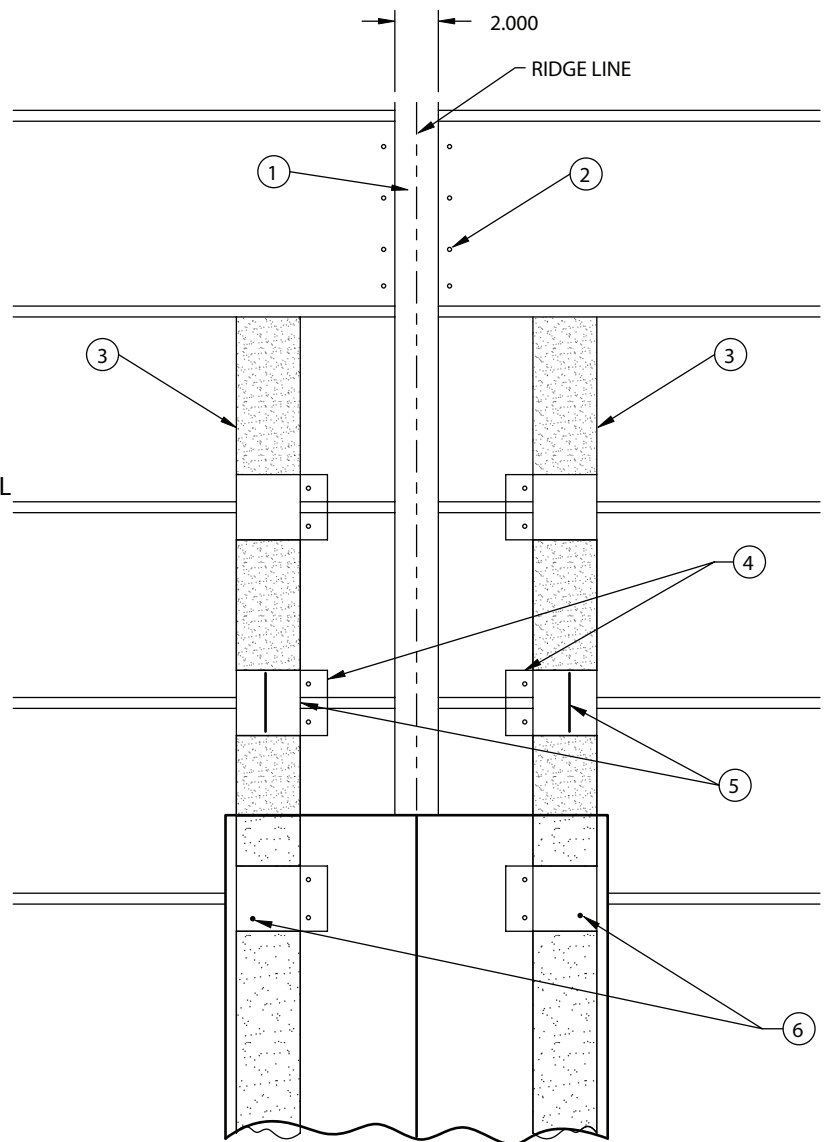

www.mwicomponents.com  
Spencer, Iowa

# INSTALLATION INSTRUCTIONS UNIVERSAL RIDGE CLIP UC175 UC150 UC100

1. ALLOW A 2" WIDE CONTINUOUS OPENING AT THE RIDGE OF THE BUILDING.
2. FASTEN THE TOP OF THE PANEL PER THE MANUFACTURERS RECOMMENDATIONS. (FASTENERS NOT PROVIDED)
3. POSITION THE UNI-VENT II™ ON THE PANEL SO THAT THE "DOWN HILL" EDGE WILL BE COVERED BY THE RIDGE CAP BY 1/2".
4. FASTEN UNIVERSAL RIDGE CLIP TO THE PANEL WITH 1 1/4 X #10 SCREWS (FASTENERS NOT PROVIDED)
5. CAULK WHERE CLIP MEETS THE SEAM AND ON FASTENING AREA OF CLIP.
6. FASTEN RIDGE CAP TO EACH UNIVERSAL RIDGE CLIP. THE STITCH SCREWS SHOULD BE PER THE MANUFACTURERS RECOMMENDATIONS. (NOT PROVIDED)



1. ALLOW A 2" WIDE CONTINUOUS OPENING AT THE RIDGE OF THE BUILDING.
2. FASTEN THE TOP OF THE PANEL PER THE MANUFACTURERS RECOMMENDATIONS.  
(FASTENERS NOT PROVIDED)
3. POSITION THE UNI-VENT II™ ON THE PANEL SO THAT THE "DOWN HILL" EDGE WILL BE COVERED BY THE RIDGE CAP BY 1/2".
4. FASTEN UNIVERSAL RIDGE CLIP TO THE PANEL WITH 1 1/4 X #10 SCREWS  
(FASTENERS NOT PROVIDED)
5. CAULK WHERE CLIP MEETS THE SEAM AND ON FASTENING AREA OF CLIP.
6. FASTEN RIDGE CAP TO EACH UNIVERSAL RIDGE CLIP. THE STITCH SCREWS SHOULD BE PER MANUFACTURERS RECOMMENDATIONS. (NOT PROVIDED)

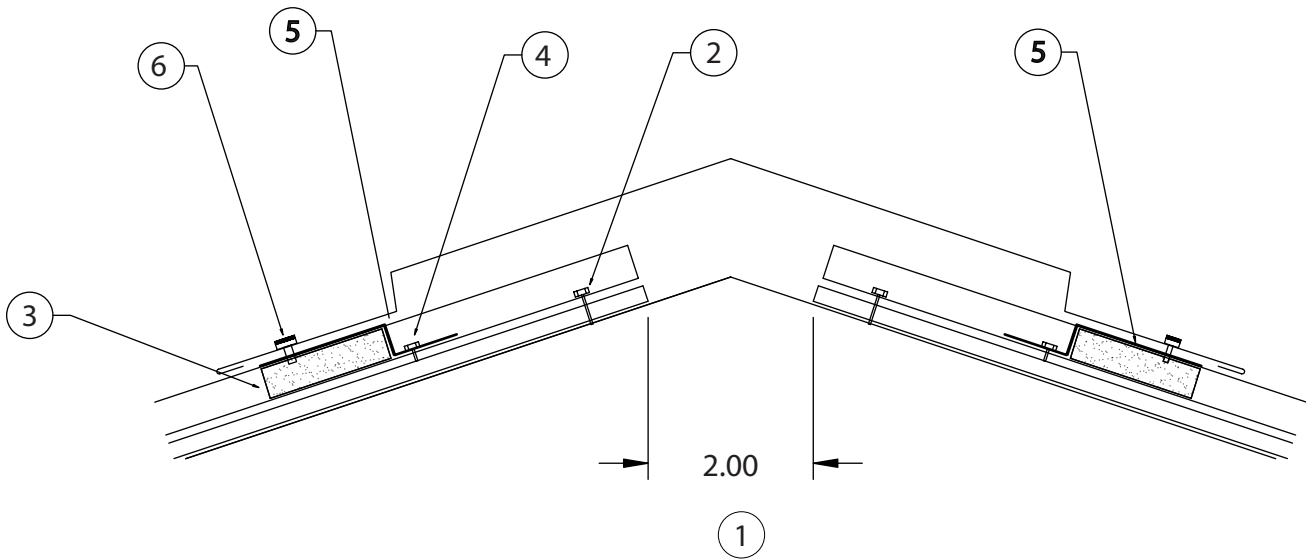

CAULK WHERE CLIP MEETS SEAM  
AND ON FASTENING AREA OF CLIP

